

# QTEX series

## Explosion Proof LED Tower Lights Flame Proof Housing

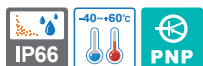

### QTEX - Standard model

Explosion proof LED tower lights with flame proof housing



**QTEX**  
Direct mount type



**QTEX**  
Wall mount type



### Common Specifications(QTEX/ QTEXB)

- Explosion proof LED tower lights with Ex d IIC rating can be used in explosive gas environments
- Excellent distance visibility by using a special reflector to aggregate the light from the LED filament
- Ø80 LED tower light mounted inside the flame proof housing
- Aluminum housing provides excellent durability
- Long-lasting high intensity LED light source
- Terminal box located inside the housing for easy power wiring
- Direct mount type and wall mount type available depending on application needs.
- Flashing rate: 60-80 flashes/min
- Selectable between steady/flashing mode with proper wire arrangement
- Sound volume : Max 95dB at 1m(QTEXB Type)
- Lens colors arrangement : ●R-Red ●A-Amber ●G-Green ●B-Blue ●W-White
- Standard housing color : Silver
- Cable entry : 3/4" NPT
- Materials : Lens-Tempered glass, Filter lens-AS, Housing-Al, Reflector-Heat resistant ABS
- Certificates : IECEx, ATEX, KCs, TIIS
- Protection rating : Ex db IIC T6 Gb, IP66
- Ambient operating temperature :  $-40^{\circ}\text{C} \leq T_{\text{amb}} \leq +60^{\circ}\text{C}$



### QTEX Explosion Proof LED Tower Lights with Flame Proof Housing

Model number	Layer	Voltage	Current	Certificate	Weight	Color
QTEX (Steady/ Flashing)	1	AC/DC12V	0.085A	    	4.01kg	● R-Red
		AC/DC24V	0.064A		4.01kg	
		AC110V-220V	Max. 0.052		4.02kg	
	2	AC/DC12V	0.150A		4.15kg	● R-Red ● G-Green
		AC/DC24V	0.099A		4.15kg	
		AC110V-220V	Max. 0.067A		4.16kg	
	3	AC/DC12V	0.210A		4.31kg	● R-Red ● A-Amber ● G-Green
		AC/DC24V	0.129A		4.31kg	
		AC110V-220V	Max. 0.083A		4.32kg	
	4	AC/DC12V	0.270A		4.46kg	● R-Red ● A-Amber ● G-Green ● B-Blue
		AC/DC24V	0.159A		4.46kg	
		AC110V-220V	Max. 0.098A		4.47kg	
5	AC/DC12V	0.330A	4.61kg	● R-Red ● A-Amber ● G-Green ● B-Blue ● W-White		
	AC/DC24V	0.189A	4.61kg			
	AC110V-220V	Max. 0.113A	4.62kg			



### Hazardous Area Classification

- **Zone 0 : Dangerous status**  
Ignitable concentrations of flammable gases or vapors which are present continuously or for long periods of time.
- **Zone 1 : Normal status**  
Ignitable concentrations of flammable gases or vapors which are likely to occur under normal operating conditions.
- **Zone 2 : Abnormal status or places**  
Ignitable concentrations of flammable gases or vapors which are not likely to occur under normal operating conditions and do so only for a short period of time.

# QTEX series

## Explosion Proof LED Tower Lights with Flame Proof Housing



### QTEXB - Built-in buzzer type



**QTEXB**

Direct mount type



**QTEXB**

Wall mount type

### **QTEXB** Built-in Siren Buzzer Type Explosion Proof LED Tower Lights with Flame Proof Housing

- Explosion proof LED tower lights with visual & audible signal that can be used in hazardous environments
- Sound tone & volume : Siren buzzer, Max 95dB at 1m

Model number	Layer	Voltage	Current	Certificate	Weight	Color
QTEXB (Steady/ Flashing)	1	AC/DC12V	0.175A	   	4.11kg	● R-Red
		AC/DC24V	0.134A		4.11kg	
		AC110V-220V	Max. 0.077A		4.12kg	
	2	AC/DC12V	0.240A		4.25kg	● R-Red ● G-Green
		AC/DC24V	0.169A		4.25kg	
		AC110V-220V	Max. 0.092A		4.26kg	
	3	AC/DC12V	0.300A		4.41kg	● R-Red ● A-Amber ● G-Green
		AC/DC24V	0.199A		4.41kg	
		AC110V-220V	Max. 0.106A		4.42kg	
	4	AC/DC12V	0.360A		4.56kg	● R-Red ● A-Amber ● G-Green ● B-Blue
		AC/DC24V	0.229A		4.56kg	
		AC110V-220V	Max. 0.121A		4.57kg	
	5	AC/DC12V	0.430A		4.71kg	● R-Red ● A-Amber ● G-Green ● B-Blue ● W-White
		AC/DC24V	0.259A		4.71kg	
		AC110V-220V	Max. 0.135A		4.72kg	

### Explosion proof structure for buzzer model

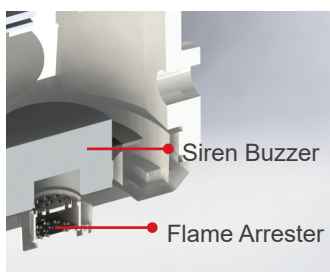

#### What is a Flame Arrester?

A flame arrester(also called a deflagration arrester) functions by absorbing the heat from a flame front traveling at sub-sonic velocities, thus dropping the burning gas/air mixture below its auto-ignition temperature: consequently, the flame cannot survive. The heat is absorbed through channels (passages) designed into an element.

### Customization

- Explosion proof cable gland attached type available (Standard type does not come with explosion proof cable gland)
- Customized cable entry (1/2"NPT, M20X1.5, M25X1.5, 1/2"PF(KCs), 3/4"PF(KCs)) available
- Two way cable entries

### Ordering Specification

<b>QTEX</b>	-	<b>3</b>	-	<b>12</b>	-	<b>RAG</b>
[Model number]		[Layer]		[Voltage]		[Color]
<ul style="list-style-type: none"> <li>• QTEX</li> <li>• QTEXB</li> </ul>		<ul style="list-style-type: none"> <li>• 1-1layer</li> <li>• 2-2layers</li> <li>• 3-3layers</li> <li>• 4-4layers</li> <li>• 5-5layers</li> </ul>		<ul style="list-style-type: none"> <li>• 12-DC12V</li> <li>• 24-DC24V</li> <li>• 110/220-AC110V-220V</li> </ul>		<ul style="list-style-type: none"> <li>● R-Red</li> <li>● A-Amber</li> <li>● G-Green</li> <li>● B-Blue</li> <li>● W-White</li> </ul>

# QTEX series

Explosion Proof LED Tower Lights with Flame Proof Housing



## Technical Diagram

(Units : mm)

QTEX/ QTEXB

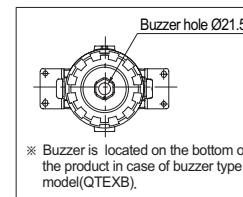
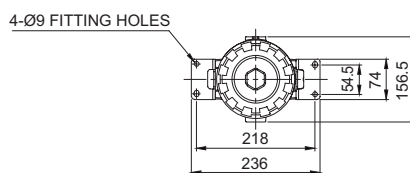
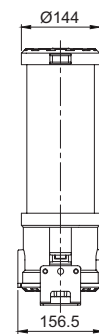
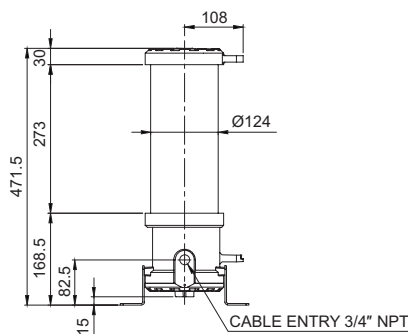

QTEX/ QTEXB – Wall mount

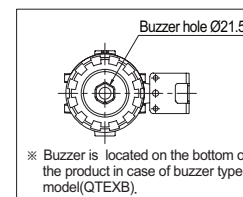
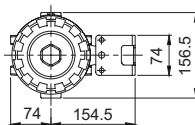
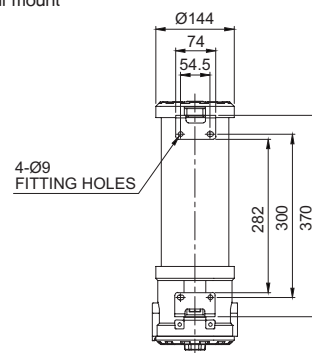
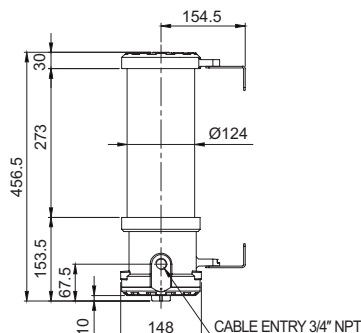

### ⚠ Cautions in using explosion proof tower lights

- Explosion proof products should be maintained by explosion proof regulation, please do not disassemble, assemble, modify or repair arbitrarily. In case disassembly is required for wiring or repair, structures such as the contact parts should maintain the same initial condition that we provided.
- Cable gland must be used in explosion proof certified products which satisfy the T6 temperature rating and IP66 protection rating.

# QTEX series

Explosion Proof LED Tower Lights with Flame Proof Housing



## Wiring Instructions

- QTEX/ QTEXB wiring with transistors and external contacts.
- In case of wiring with transistors, please use PNP transistors and wiring exactly following below technical diagram.
- Product can be wired regardless of polarity.

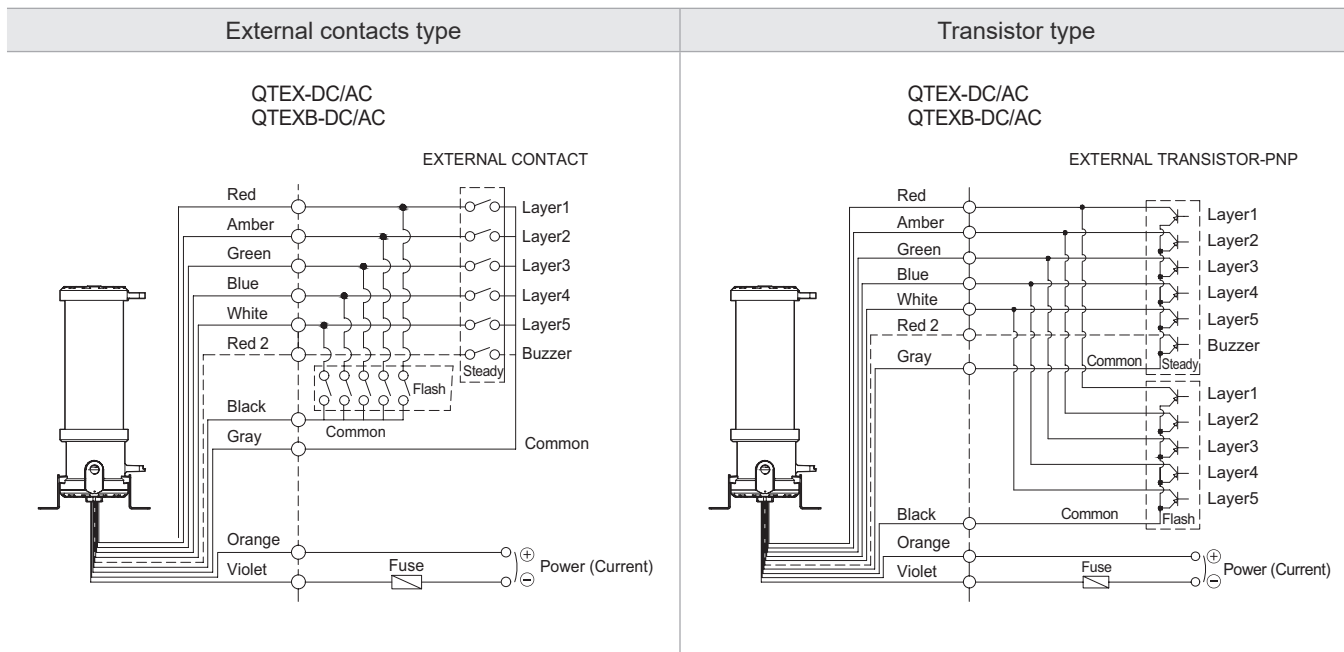

## Terminal Wiring Information

